

EMD SERIES

ELECTRONIC CONDENSATE DRAIN

operating pressure	16 bar
drain capacity	12 l/h
inlet connection	1/2"
operating temp. range	1,5 to 65°C



APPLICATIONS

- air compressor (piston or screw)
- after-cooler
- cyclone condensate separator
- pressure vessel/air tank
- air dryer
- air filter

ADVANTAGES

- ✓ integrated strainer (easy access/cleaning)
- ✓ compact design
- ✓ direct acting, self cleaning valve (patented)
- ✓ optimised for easy service (service kit)
- ✓ horizontal or vertical installation
- ✓ PA housing

**PATENTED VALVE
TECHNOLOGY**

DESCRIPTION

EMD12 series drain have developed for fully automatic discharging of condensate or any other non-aggressive fluid from compressed air system. The units can be installed as external drain on any application specified. Condensate accumulates in the collecting reservoir. When the level is high enough condensate is being discharged from the system without any air losses. Fluid level is detected by precise capacitive level sensor. Special self-cleaning direct acting valve assures reliable operating. EMD series is also equipped with operation alarm, led indicator, test button and internal strainer. Version with Service Network for diagnostics parameter setting and alarm output is also available.



Technical data	EMD 12	EMD 12C	EMD 12	EMD 12C
Service network connection option	No	Yes	No	Yes
Voltage	230 VAC		115 VAC	
Fuse	5 x 20 1A T		5 x 20 1A T	
Power	10 VA			
Frequency	50-60 Hz			
Operating pressure range	0-16 bar (0 - 232 psi)			
Drain capacity (at 7 bar/101 psi)	12 l/h (0,007 cfm)			
Operating temperature range	1,5 - 65 °C (35-149 °F)			
Inlet connection	G 1/2"			
Outlet connection	Push connection for tube ø8			
Protection class	IP54			
Mass [kg]	0,550			
Dimensions A x B x C [mm]	133 x 76 x 147			
Peak compressor capacity [m³/min]	a	8,8		
	b	7,4		
	c	4,6		
Peak dryer capacity [m³/min]	a	18,56		
	b	14,9		
	c	9,28		
Peak filter capacity [m³/min]	a	92,8		
	b	74,4		
	c	46,4		

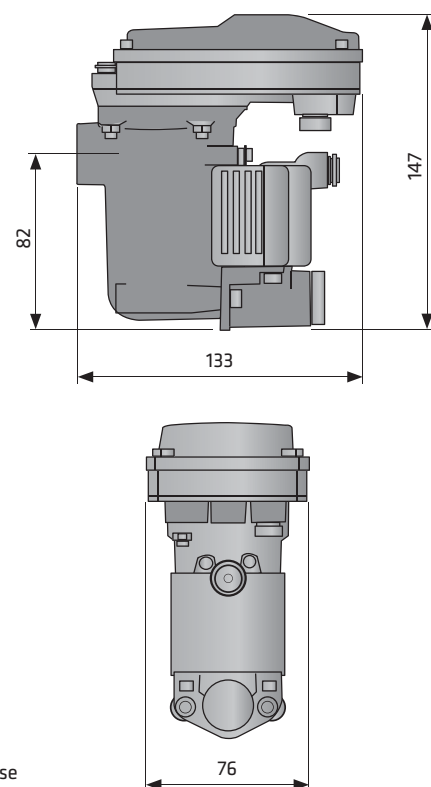

The amount of condensed water in compressed air system depends mainly on outside air temperature. Please take the relevant climate zone into account when dimensioning yours specific EMD-12 drain series application:

- a Northern Europe, Canada, Central Asia
- b Rest of the World
- c Moist tropical and subtropical regions